



Preliminary

EIM6775-5

ISSUED 10/09/2008

6.7 – 7.5 GHz Multi-Stage Power Amplifier

FEATURES

- 6.7– 7.5GHz Operating Frequency Range
- 37.0dBm Output Power at 2dB Compression
- 31.0 dB Typical Power Gain @2dB gain compression
- Non-Hermetic Metal Flange Package

APPLICATIONS

- Point-to-point and point-to-multipoint radio
- Military Radar Systems

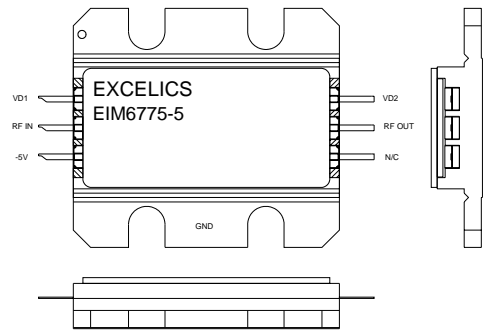

Caution! ESD sensitive device.

ELECTRICAL CHARACTERISTICS (T_b = 25 °C, 50 ohm, VD1=7V, VD2=10V, V_{gg}=-5V)

SYMBOL	PARAMETER/TEST CONDITIONS	MIN	TYP	MAX	UNITS
F	Operating Frequency Range	6.7		7.5	GHz
P2dB	Output Power at 2dB Gain Compression	36.0	37.0		dBm
G2dB	Gain @2dB gain compression	29	31		dB
ΔGain	Gain Flatness		±1.0		dB
Input RL	Input Return Loss		-12	-8	dB
Output RL	Output Return Loss		-15	-10	dB
VD1	Drain Supply Voltage 1		7		V
VD2	Drain Supply Voltage 2		10		V
I_{DQ1}	Quiescent Drain Current 1		200		mA
I_{DQ2}	Quiescent Drain Current 2		2600	3000	mA
V_{gg}	Gate Supply Voltage		-5		V
R_{th}	Thermal Resistance		2.4		°C/W
T_b	Operating Base Plate Temperature	- 30		+ 80	°C

Specifications are subject to change without notice.

Excelics Semiconductor, Inc. 310 De Guigne Drive, Sunnyvale, CA 94085
 Phone: 408-737-1711 Fax: 408-737-1868 Web: www.excelics.com

page 1 of 3
 October 2008

MAXIMUM RATINGS @25°C^{1,2}

SYMBOL	CHARACTERISTIC	ABSOLUTE	CONTINUOUS ^{1,2}
V _{D1}	Drain Supply Voltage ¹	12V	8V
V _{D2}	Drain Supply Voltage ²	14V	10V
V _{gg}	Gate Supply Voltage	-10V	-6 V
I _{gg}	Gate Current	150mA	50 mA
P _{IN}	Input Power	20dBm	@ Pout 2dB compression
T _{CH}	Channel Temperature	175°C	175°C
T _{STG}	Storage Temperature	-65/175°C	-65/175°C
P _T	Total Power Dissipation	37.5W	37.5W

Notes: 1. Operating the device beyond any of the above rating may reduce MTTF and cause permanent damage.
 2. Bias conditions must also satisfy the following equation $V_{dd} \cdot I_{dd} < (T_{CH} - T_b) / R_{TH}$

Package Dimension and Pin Assignment

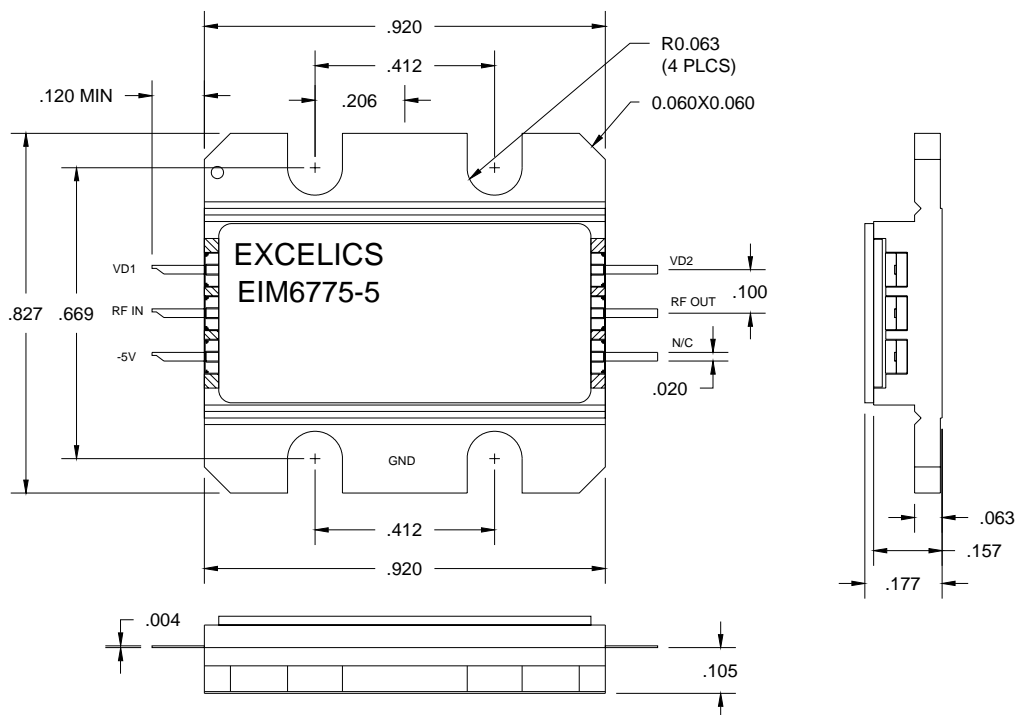

Dimensions are in inches
 * NC: No connection inside the package

Application Note

1. The package should be screwed onto a good heat sink and ground
2. Turn on/off sequence is required:
 - to turn on: apply -5V first, then +7V and +10V.
 - to turn off: turn +7V and +10V off first, then turn -5V off
3. Recommended External Bias Circuit and Internal Block Diagram

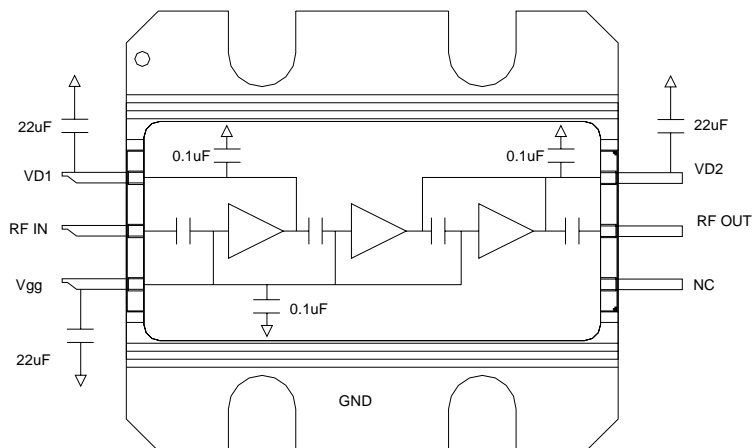

Typical Performance:

TBD

S-PARAMETERS

TBD

DISCLAIMER

EXCELICS SEMICONDUCTOR RESERVES THE RIGHT TO MAKE CHANGES WITHOUT FURTHER NOTICE TO ANY PRODUCTS HEREIN TO IMPROVE RELIABILITY, FUNCTION OR DESIGN. EXCELICS DOES NOT ASSUME ANY LIABILITY ARISING OUT OF THE APPLICATION OR USE OF ANY PRODUCT OR CIRCUIT DESCRIBED HEREIN.

LIFE SUPPORT POLICY

EXCELICS SEMICONDUCTOR PRODUCTS ARE NOT AUTHORIZED FOR USE AS CRITICAL COMPONENTS IN LIFE SUPPORT DEVICES OR SYSTEMS WITHOUT THE EXPRESS WRITTEN APPROVAL OF EXCELICS SEMICONDUCTOR, INC.

AS HERE IN:

1. Life support devices or systems are devices or systems which, (a) are intended for surgical implant into the body, or (b) support or sustain life, or (c) whose failure to perform when properly used in accordance with instructions for use provided in the labeling, can be reasonably expected to result in significant injury to the user.
2. A critical component is any component of a life support device or system whose failure to perform can be reasonably expected to cause the failure of the life support device or system, or to affect its safety or effectiveness.