



EMP103

ISSUED DATE: 07-12-04

6.4 – 8.0 GHz Power Amplifier MMIC

FEATURES

- 6.4 – 8.0 GHz Operating Frequency Range
- 32.5dBm Output Power at 1dB Compression
- 15.0 dB Typical Small Signal Gain
- -40dBc OIMD3 @Each Tone Pout 22dBm

APPLICATIONS

- Point-to-point and point-to-multipoint radio
- Military Radar Systems

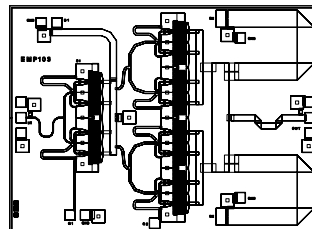

Dimension: 2200um X 3000um
Thickness: 65um ± 15um



Caution! ESD sensitive device.

ELECTRICAL CHARACTERISTICS ($T_a = 25\text{ }^\circ\text{C}$, 50 ohm, $V_{DD}=10\text{V}$, $IDQ=1000\text{mA}$)

SYMBOL	PARAMETER/TEST CONDITIONS	MIN	TYP	MAX	UNITS
F	Operating Frequency Range	6.4		8.0	GHz
P1dB	Output Power at 1dB Gain Compression	31.5	32.5		dBm
Gss	Small Signal Gain	13.0	15.0		dB
OIMD3	Output 3 rd Order Intermodulation Distortion @ $\Delta f=10\text{MHz}$, Each Tone Pout 22dBm		-40.0		dBc
Input RL	Input Return Loss		-15	-10	dB
Output RL	Output Return Loss		-6		dB
Idss	Saturate Drain Current $V_{DS}=3\text{V}$, $V_{GS}=0\text{V}$		1680		mA
V _{DD}	Power Supply Voltage		10		V
Rth	Thermal Resistance (Au-Sn Eutectic Attach)		7		$^\circ\text{C/W}$
Tb	Operating Base Plate Temperature	-35		+80	$^\circ\text{C}$

ABSOLUTE MAXIMUM RATINGS FOR CONTINUOUS OPERATION^{1,2}

SYMBOL	CHARACTERISTIC	VALUE
V _{DS}	Drain to Source Voltage	10V
V _{GS}	Gate to Source Voltage	-4V
I _{DD}	Drain Current	Idss
I _{GSF}	Forward Gate Current	35 mA
P _{IN}	Input Power	@ 3dB compression
T _{CH}	Channel Temperature	150 $^\circ\text{C}$
T _{STG}	Storage Temperature	-65/150 $^\circ\text{C}$
P _T	Total Power Dissipation	17W

1. Operating the device beyond any of the above rating may result in permanent damage.

2. Bias conditions must also satisfy the following equation $V_{DS} \cdot I_{DS} < (T_{CH} - T_{HS})/R_{TH}$; where T_{HS} = ambient temperature

Specifications are subject to change without notice.

Excelics Semiconductor, Inc. 310 De Guigne Drive, Sunnyvale, CA 94085

Phone: 408-737-1711 Fax: 408-737-1868 Web: www.excelics.com

page 1 of 2
Revised July 2004

ISSUED DATE: 07-12-04

6.4 – 8.0 GHz Power Amplifier MMIC

ASSEMBLY DRAWING

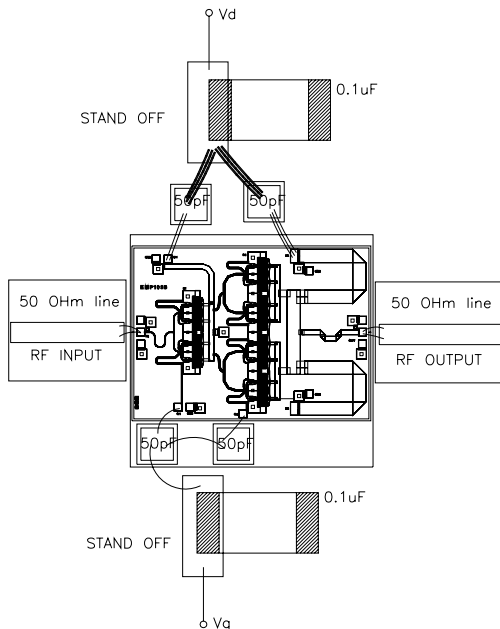

CHIP OUTLINE

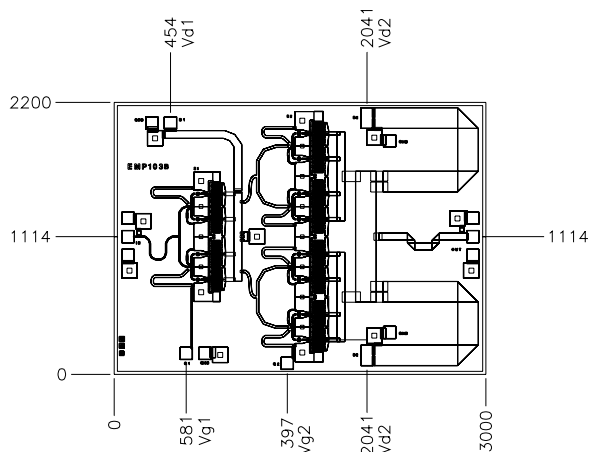

All Dimensions in Microns

TYPICAL PERFORMANCE

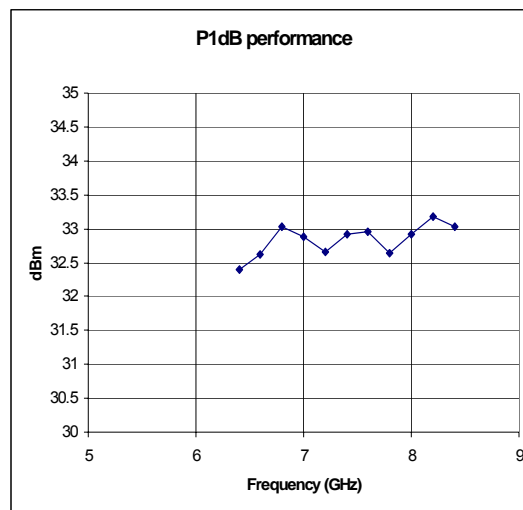
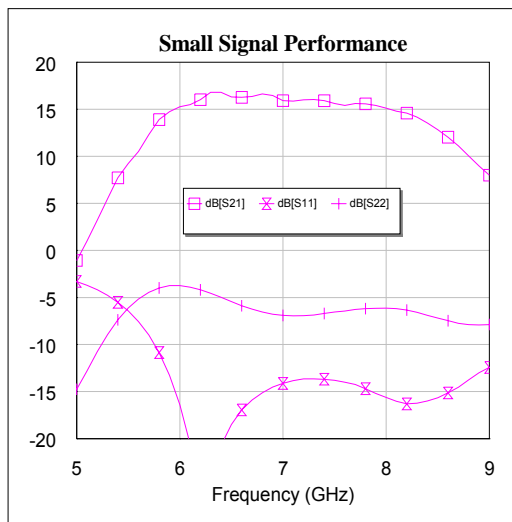

Data measured @ $V_d=10V$, $I_d=950mA$

Specifications are subject to change without notice.

Excelics Semiconductor, Inc. 310 De Guigne Drive, Sunnyvale, CA 94085
Phone: 408-737-1711 Fax: 408-737-1868 Web: www.excelics.com

page 2 of 2
Revised July 2004